

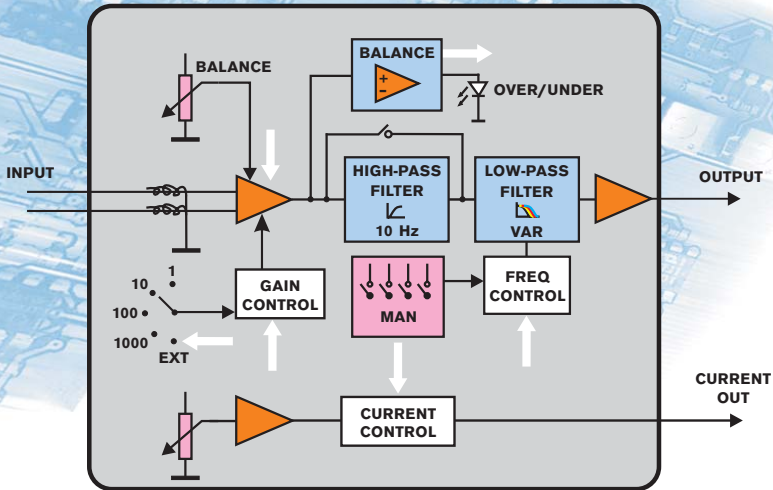

# Hall Probes Driver Model HPD 4.1



HPD 4.1 is a modular system for measurement of magnetic field by means of Hall probes with high temporal resolution. It consists of a system unit (enclosure, power supply), 1 to 4 Hall probe modules, 1 temperature module and 1 communication module. The system is mounted in a standard 19 inch rack. This driver is primarily designed for magnetic field measurement in fusion research (tokamaks, stellarators), but its application is much broader (industry, R&D).



### Hall probe module 2301

The Hall probe module was designed to supply one Hall probe with DC current up to 200 mA and to measure input signal from the probe. The input circuits involve precision input gain amplifier with the gain 1 to 10000, high-pass 10 Hz filter and a programmable low-pass filter with 4 cut-out frequencies (1 kHz to 350 kHz). The output signal is balanced manually, unbalanced signal is indicated by two LEDs. The output signal is an analogue voltage signal proportional to magnetic field, which is corrected by frequency filters. The input signal connector (mixed D-sub) incorporates the signal from PT100 temperature sensor. It is useful for simultaneous measurement of the temperature near the magnetic sensor. All parameters can be set either manually or remotely via a communication module.



### Temperature module 2302

The temperature module enables to perform temperature measurements by means of PT100 sensor. The calibrated range is 0 °C to 100 °C (see technical data). The input can be either direct (via insulated BNC located on the temperature module) or via mixed D-sub input connectors located on HPD modules. Each of the Hall probe modules can be used for temperature measurements. The output signal is 10 mV/°C and 0 V for 0 °C.

### Communication module 2303

This module is available in multiple versions depending on the form of communication protocol used between the master computer and HPD 4.1. Please, ask the manufacturer for details.



### Power supply module 2205

This module provides power supply to the entire system. Power status is indicated by an illuminated green push-pull switch.

## Parameters

Input amplifier gain	1×, 10×, 100×, 1000×
Total gain	10×, 100×, 1000×, 10000×
Input voltage	0 to ±0.5 V
Max. output voltage	±0.5 V
High-pass filter	10 Hz
Low-pass filter	1 kHz, 10 kHz, 100 kHz, 350 kHz
Order of active low-pass filter	4
Output current	0 to 200 mA
Output current stability (for $\Delta R = 50 \Omega$ )	1%
Setting accuracy (real value vs value on the potentiometer scale)	±1%
Standard accuracy (main accuracy)	0.3%
Additional accuracy (caused by temporal changes)	0.01%/°C for total gain 10 0.01%/°C for total gain 100 0.02%/°C for total gain 1000 0.03%/°C for total gain 10000
Setting time (recommended time after power-on before exact measurement)	10 min

Temperature probe	PT100
Temperature range	-200 to 200 °C
Calibrated range	0 to 100 °C
Output voltage	10 mV/°C and 0 V for 0 °C
Standard accuracy	±0.3% ±1 digit
Additional accuracy	0.02%/K

Power	230 VAC, 50/60 Hz, 20 VA
Dimensions (system unit)	19" × 3U × 280 mm
Weight (system unit)	8 kg